

Tension-Compression Load Cell

Model 8435

Code:	8435 E
Manufacturer:	burster
Delivery:	ex stock/6 weeks
Warranty:	12 months
Issue:	1.9.2001



- Available ranges from 0 ... 200 N up to 0 ... 5000 N
- Accuracy < 0,25 %
- Small dimensions
- Simple mounting
- Material: stainless steel
- Tension and compression load

Application

This tension and compression load cell dynamometer is designed as a compact and universal sensor delivering high precision at a low price.

Made of high-grade steel, the sensor has small dimensions and allows easy assembly into existing structures where static and dynamic forces need to be measured.

This load sensor is used typically for measuring forces, weights, coefficients of friction, sliding friction and adhesion on fitting devices, manipulators, coupling mechanisms, loading machines and operating devices.

Description

This model of load cell uses proven strain gage technology to perform measurements. Straining gages are applied to the sensitive element and connected to form a full bridge. The electrical resistance of this full bridge increases with the load acting on it, so that the bridge supplies an output voltage proportional to the measurement variable.

This model allows the application of two types of force: compression via the load application button and tension via the centric internal thread. The measurement range of 0 ... 5000 N is supplied exclusively with the integrated load application button. The sensor has to be mounted on a level surface using screws fitted through the three boreholes in the outer ring.

To achieve the highest possible measurement accuracy, the sensor should not be subjected to lateral forces.

A strain-relief and an anti-bend mechanism for the connection cable are integrated in the sensor housing.

Technical Data

Order Code	Measuring Range	Natural Frequency [kHz]
8435 - 5200	0 ... 200 N	5,0
8435 - 5500	0 ... 500 N	9,0
8435 - 6001	0 ... 1000 N	14,0
8435 - 6002	0 ... 2000 N	18,0
8435 - 6005	0 ... 5000 N	22,0

Electrical Values

Bridge resistance (full bridge circuit): foil strain gage 350 Ω, nominal ¹⁾
 Calibration resistor: The bridge output signal resulting from a shunt of this value is shown in the calibration certificate
 Excitation: recommended 5 VDC
 range 0 ... 200 N maximum 5 VDC
 range ≥0 ... 500 N maximum 10 VDC
 Sensitivity: 1 mV/V, nominal¹⁾
 Insulating resistance: > 10 MΩ
¹⁾ Deviations from stated value are possible.

Environmental Conditions

Temperature operating: - 30 °C ... 80 °C
 Temperature compensated: 15 °C ... 70 °C
 Temperature effect zero shift: ≤ ± 0.02 % F.S./K
 Temperature effect span shift: ≤ + 0.03 % Rdg./K

Mechanical Data

Non-linearity: < 0.25 % F.S.
 Hysteresis: < 0.20 % F.S.
 Non-repeatability: < 0.15 % F.S.
 Kind of measurement: Tension and compression, calibration in compression direction, range 0 ... 5000 N compression only
 Deflection full scale: approx. 60 μm
 Overload safe: 50 % over capacity
 Overload burst: 100 % over capacity
 Construction: bending diaphragm
 Dynamic performance: recommended 50 % of capacity
 maximum 70 % of capacity
 Material: stainless steel 1.4542
 Electrical termination: shielded, 4-leaded TPE-isolated cable with bare ends for soldering; additional buckling protector; length approx. 2 m bending radius > 30 mm
 Protection class: according to DIN 40050 IP 54
 Wiring code:
 white Excitation (positive)
 brown Excitation (negative)
 yellow Output (positive)
 green Output (negative)
 Dimensions: see scale drawing
 Weight: approx. 40 g without cable

Order Information

Tension and compression load cell, range 0 ... 500 N: (see table). **Model 8435 - 5500**

Accessories

Load button for introduction of compression force, made of stainless steel, HRC 50. **Model 8580-V004**
 Pull plate, material and design as load cell. **Model 8590-V001**
 Mating connector (12 pins) to all burster instrumentations in table housing. **Model 9941**
 Mounting of mating connector to conductor cable. **Model 99004**
 Amplifiers, sensor supplying instruments as e.g. digital measuring indicator series 9162, modular amplifier model 9243 and process controllers. **See section 9 of the catalog**

DMS Simulator

Support accessories for creating strain gage source signals in order to adjust amplifiers and monitors.

Model 9405

Option

Standardization of sensitivity to 1.0 mV/V, done in conductor cable.

Order code: V010

Load Button Model 8580-V004

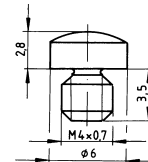

Scale Drawing

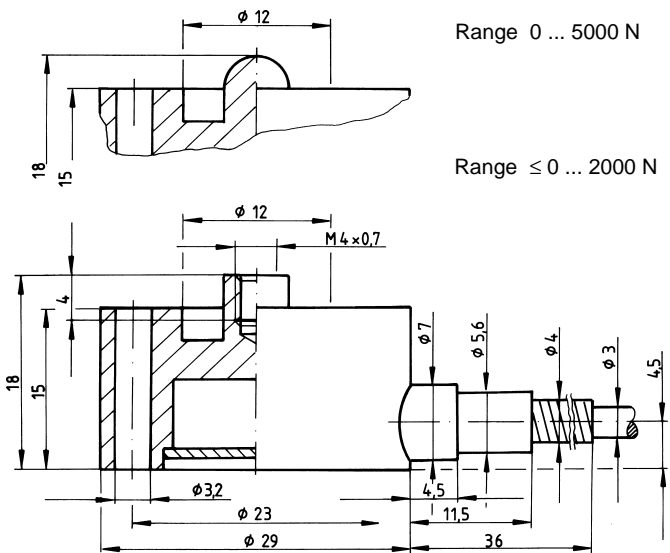

Built-in Illustration

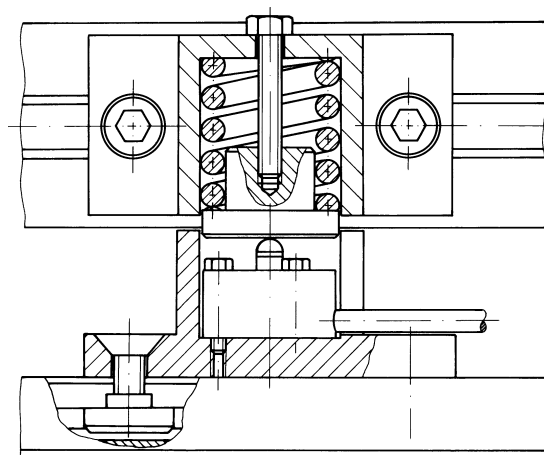

Overload of the load cell is impossible due to a suitable spring. When the units are locked the spring will transfer not more load to the cell than the measuring range can cope with.