

Torque Sensor Square Shaft Slip Rings

Model 86402

Code:	86402 E
Manufacturer:	burster
Delivery:	4 weeks
Warranty:	12 months
Issue:	1.10.2002

CAD-Daten by web2CAD
 Infos: Data sheet 80-CD-ROM-E



- Measurement ranges 0 ... ± 6 Nm to 0 ... ± 1000 Nm
- With or without integrated angular measurement
- Compact design
- Speeds of up to 3000 min⁻¹ (short-term)
- Self-lubricating slip rings and high-grade hard-silver brushes

Application

This model series allows reliable and accurate measurements of static and dynamic torques in both directions of rotation, making it suitable for a large number of applications. The variants of this series constitute standard equipment for quality control, production, assembly and laboratory tests.

Typical applications:

- ▶ Screw joint technologies
 - Checking and adjustment of screw tools such as angled torque spanners or screw instruments
 - Testing of screw connections
- ▶ Measurement of
 - Drag moments on motors and pumps
 - Friction moments on gearboxes, bearings and seals
 - Torsion springs
 - Adjustment devices in the automobile industry (sliding roofs, window lifters etc.)

Description

4 strain gauges are mounted and connected to form a full bridge on a steel sensor element, in the center of the rotatable shaft. The electrical power supply for the strain gauge full bridge and the measurement signals are transmitted between rotor and stator via a high-grade, 4-fold slip ring system.

Measurement signals are positive for right-hand torques and negative for left-hand torques.

For optional angular measurement, variants 86402-...-V 501 are equipped with a pulse disc. The 2 pulse rows displaced by 90° allow directions of rotation to be identified.

The sensor characteristic values are standardized (1 resp. 2 mV/V) to facilitate tests of the connected amplifier and sensor replacement.

86402-E

Technical specifications

Model 86402, socket wrench torque sensor

Order code	Measuring range	Sensitivity [mV/V]	Square profile	A	B	C	D	E	F	H	I	L	N	Permissible axial load[N]	Weight [kg]
86402-5006	0 ... ± 6 Nm	1.0	1/4"	75	28	50	58	14	8.5	5	11	13	-	150	0.3
86402-5012	0 ... ± 12 Nm	2.0	1/4"	75	28	50	58	14	8.5	5	11	13	-	150	0.3
86402-5025	0 ... ± 25 Nm	2.0	3/8"	74.5	38	58	44	19	13.5	6	22	25	17	550	0.3
86402-5063	0 ... ± 63 Nm	2.0	3/8"	74.5	38	58	44	19	13.5	6	22	25	17	1000	0.3
86402-5160	0 ... ± 160 Nm	2.0	1/2"	79	38	58	44	19	18	6	22	25	17	1800	0.35
86402-5500	0 ... ± 500 Nm	2.0	3/4"	97	58	76	50	29	30	5	25	40	30	4000	0.8
86402-6001	0 ... ± 1000 Nm	2.0	1"	112	73	90	57	36.5	34.5	5	28.5	50	40	6000	1.4

Model 86402-...-V501, socket wrench torque sensor with angle encoder

Order code	Measuring range	Sensitivity [mV/V]	Square profile	A	B	C	D	E	F	G	H	I	K	L	N	Permissible axial load[N]	Weight [kg]
86402-5006-V501	0 ... ± 6 Nm	1.0	1/4"	75	28	52	58	14	8.5	8	5	11	-	13	-	150	0.3
86402-5012-V501	0 ... ± 12 Nm	2.0	1/4"	75	28	52	58	14	8.5	8	5	11	-	13	-	150	0.3
86402-5030-V501	0 ... ± 30 Nm	2.0	3/8"	101	38	58	59	19	21.5	14	5	12	35	25	17	550	0.6
86402-5063-V501	0 ... ± 63 Nm	2.0	3/8"	101	38	58	59	19	21.5	14	5	12	35	25	17	1000	0.6
86402-5160-V501	0 ... ± 160 Nm	2.0	1/2"	106	38	58	59	19	26	14	5	12	35	25	17	1800	0.6
86402-5500-V501	0 ... ± 500 Nm	2.0	3/4"	135	58	76	64	29	40	30	5	14	36	40	30	4000	1.5
86402-6001-V501	0 ... ± 1000 Nm	2.0	1"	177	73	90	73	36.5	57.5	45	5	14	45	50	40	6000	2.7

Electrical values

Bridge resistance (full-bridge foil strain gauge): 350 Ω, nominal
 Excitation: max. 12 V DC or AC
 Output at rated capacity (sensitivity): 1 mV/V or 2 mV/V, refer to the tables

H Output 2 angle sensor (TTL-pulses)
 I GND
 M Screen Shield (not connected in the sensor)

Scale drawing

Ambient conditions

Operating temperature range: + 5 °C ... + 50 °C
 Temperature influence
 On zero signal: 0,015 % full scale/K
 On sensitivity: 0,015 % full scale/K

Mechanical values

Non-linearity: < ± 0.2 % full scale
 Hysteresis: < ± 0.1 % full scale
 Repeatability: < ± 0.05% full scale
 Max. useful moment: max. 150 % of rated capacity
 Speed range: max. 3000 min⁻¹ short-term
 Oscillation width (peak-to-peak): max. 70 % full scale
 Max. acceleration: 100 g
 Housing material: Very strong anodized aluminium
 Protection in accordance with DIN 40050: IP 40
 Dimensions: Refer to the tables and scale drawings

Maintenance:

Cleaning cycle (slip ring wear): After approx (5-10)·10⁶ revolutions
 Brush replacement: After approx (50-100)·10⁶ revolutions
 Mechanical connection: Inner and outer square profile in compliance with DIN 3126 for coupling screw tools

Electrical connection:

Sensor without angular encoder

6-pole plug connection, model 9953 mating connector
 Pin assignment: 1 Negative feed (for instance: - 5 VDC)
 2 Positive feed (for instance: + 5 VDC)
 3 Shield (not connected in the sensor)
 4 Positive output
 5 Negative output
 6 Test

Sensor with angular encoder

12-pole plug connection, model 9940 mating connector

Pin assignment: A Negative excitation
 B Positive excitation
 C Positive output
 D Negative output
 E Ground excitation angle sensor
 F 5 V excitation angle sensor
 G Output 1 (TTL-pulses) angle sensor

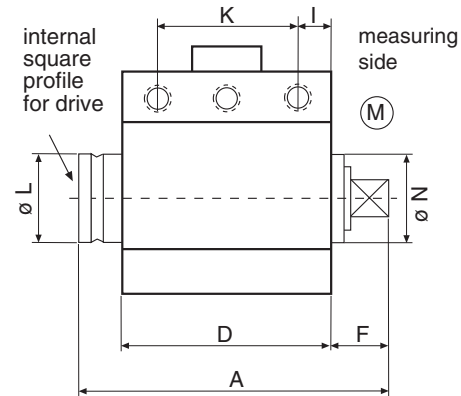

Sensor CAD drawing can be imported from CD-ROM or downloaded from the Internet.

For more information about **POWERPARTS** please refer to the introduction of section 8 in the catalog.

Accessories

for sensors without angle encoder

Mating connector (cable coupling), 6-pole, included in the scope of delivery **model 9953**

Connection cable with one free end, 3m long **model 99553-000A-011 00 30**

Connection cable for burster desktop instruments, 3m long **model 99141-553A-015 00 30**

for sensors with angle encoder

Mating connector, 12-pole, included in the scope of delivery **model 9940**

Connection cable with one free end, 3m long **model 99540-000K-027 00 30**

Connection cable for 9306 desk top, 3m long **model 99141-540K-027 00 30**

Model 9405 strain gauge simulator

The sensor is replaced by the strain gauge simulator for adjusting or checking the amplifier / digital display.

The supply units, amplifier and process monitoring units such as the model 9243 module amplifier, model 9180 digital display and model 9306 DIGIFORCE® are described in **product group 9 of the catalog**.