

Precision Torque Sensor

Non-contact transmission for rotating applications

Optional measurement of angle and speed

Code:	8661 EN
Delivery:	2 - 3 weeks
Warranty:	24 months

Model 8661



Optional:

- ▶ USB interface
- ▶ Dual range

- Measuring range 0 ... ± 0,02 Nm to 0 ... ± 1000 Nm
- Low linearity deviation of ≤ ± 0.05 % F.S.
- Intelligent operating state indicator
- 16 bit D/A- converter including digital adjustment
- Output signal 0 ... ±10 V (optional 0 ... ± 5 V)
- Angle measurement with 2000 increments / 0.045° (option)
- Speed measurement to 25 000 min⁻¹ (option)
- High performant software (option USB) including mechanical power computation, multichannel operation, freely editable mathematical auxiliary channel
- Excellent price-performance ratio
- From 500 Nm 4 x keyway (optionally in other measuring ranges possible)

Application

The series 8661 precision torque sensor is the ideal choice for reliable measurement of static and dynamic clockwise and counter-clockwise torques.

Thanks to the non-contact transmission of the excitation voltage and measurement signal, the sensor offers virtually maintenance-free and fail-safe operation. This makes it perfect for industrial production and assembly applications where there is a need to measure actuating or breakaway torques, holding torques or tightening torques.

Its high measurement quality means that the sensor is equally suited to quality control applications and laboratory-based research and development projects.

The applied torque can be read easily by evaluation units or controllers connected to the normalized analog interface.

For network-independent, mobile use, the torque sensor offers an optional USB interface. This can be connected to a notebook running the PC software supplied with the device to take on-site measurements with accompanying visualization and archival of measurement values.

Its compact, robust and vibration-proof construction makes it suitable for use in the following example applications:

- ▶ Test setups for precision mechanics
- ▶ Measurements on micromechanical actuator elements
- ▶ Engine test benches including measurement of mechanical power
- ▶ Recording biomechanical movements in medical engineering
- ▶ Precision frictional torque measurements on bearings
- ▶ Use as test-bench measuring device

Description

The measuring shaft, which is made of high-quality materials, carries metal-film strain gauges. Torsion of the shaft by the torque to be measured produces a change in resistance in the full bridge, which is converted into a measurement signal that is proportional to the torque.

To ensure wear-free operation, the power is supplied by inductive coupling and the measurement signals are transmitted optically.

The signal, which has been digitized already on the shaft, is converted and amplified into a 0 ... ± 10 V signal by a 16 bit digital-to-analog converter on the stator. A high-resolution TTL output signal for the angular displacement and rotational speed measurement is achieved by optical sensing of an incremental encoder disk with up to 1024 divisions and two offset tracks plus four-edge decoding.

An extra socket in addition to the standard 12 pin connector provides another option for connecting an external supply. Continuous, online display of the various operating states is provided by a 3 LED optical indicator.

High-quality bearings, tight manufacturing tolerances and excellent balance are essential for achieving the optimum running stability that this sensor delivers at speeds of over 25 000 rpm.

Technical Data
Table 1

Order Code	L2	L3	L4	B1	H	H1	D1	D2	D3	D4		A1	A2	A3	T1		T2		A4	A5	N1	N2
										Ø	deep				deep	deep						
8661-4020-VXXXX	10	66	11	40	60	15	5	8	29	3.1	5	45	31	30	M4	8	M3	5,5	26	24	1.5	0
8661-4050-VXXXX	10	66	11	40	60	15	5	8	29	3.1	5	45	31	30	M4	8	M3	5,5	26	24	1.5	0
8661-4100-VXXXX	10	66	11	40	60	15	5	8	29	3.1	5	45	31	30	M4	8	M3	5,5	26	24	1.5	0
8661-4200-VXXXX	10	66	11	40	60	15	5	8	29	3.1	5	45	31	30	M4	8	M3	5,5	26	24	1.5	0
8661-4500-VXXXX	10	66	11	40	60	15	5	8	29	3.1	5	45	31	30	M4	8	M3	5,5	26	24	1.5	0
8661-5001-VXXXX	10	66	11	40	60	15	5	8	29	3.1	5	45	31	30	M4	8	M3	5,5	26	24	1.5	0
8661-5002-VXXXX	14	66	14	40	60	15	6	8	29	3.1	5	45	31	30	M4	8	M3	5,5	26	24	1.5	0
8661-5005-VXXXX	30	83	30	55	85	27.5	15	15	54	3.1	5	57	44	41	M5	9	M4	6	45.3	45.3	1.5	0
8661-5010-VXXXX	30	83	30	55	85	27.5	15	15	54	3.1	5	57	44	41	M5	9	M4	6	45.3	45.3	1.5	0
8661-5020-VXXXX	30	83	30	55	85	27.5	15	15	54	3.1	5	57	44	41	M5	9	M4	6	45.3	45.3	1.5	0
8661-5050-VXXXX	45	78	45	64	94	32	26	26	58.5	3.1	5	57	44	41	M5	8	M4	6	54.4	54.4	3	3
8661-5100-VXXXX	45	78	45	64	94	32	26	26	58.5	3.1	5	57	44	41	M5	8	M4	6	54.4	54.4	3	3
8661-5200-VXXXX	45	78	45	64	94	32	26	26	58.5	3.1	5	57	44	41	M5	8	M4	6	54.4	54.4	3	3
8661-5500-VXXXX	96.25	95	96.25	107	137	53,5	45	45	97	4.1	10	50	90	30	M8	20	M6	10	88.4	88.4	2.5	2.5
8661-6001-VXXXX	96.25	95	96.25	107	137	53,5	45	45	97	4.1	10	50	90	30	M8	20	M6	10	88.4	88.4	2.5	2.5

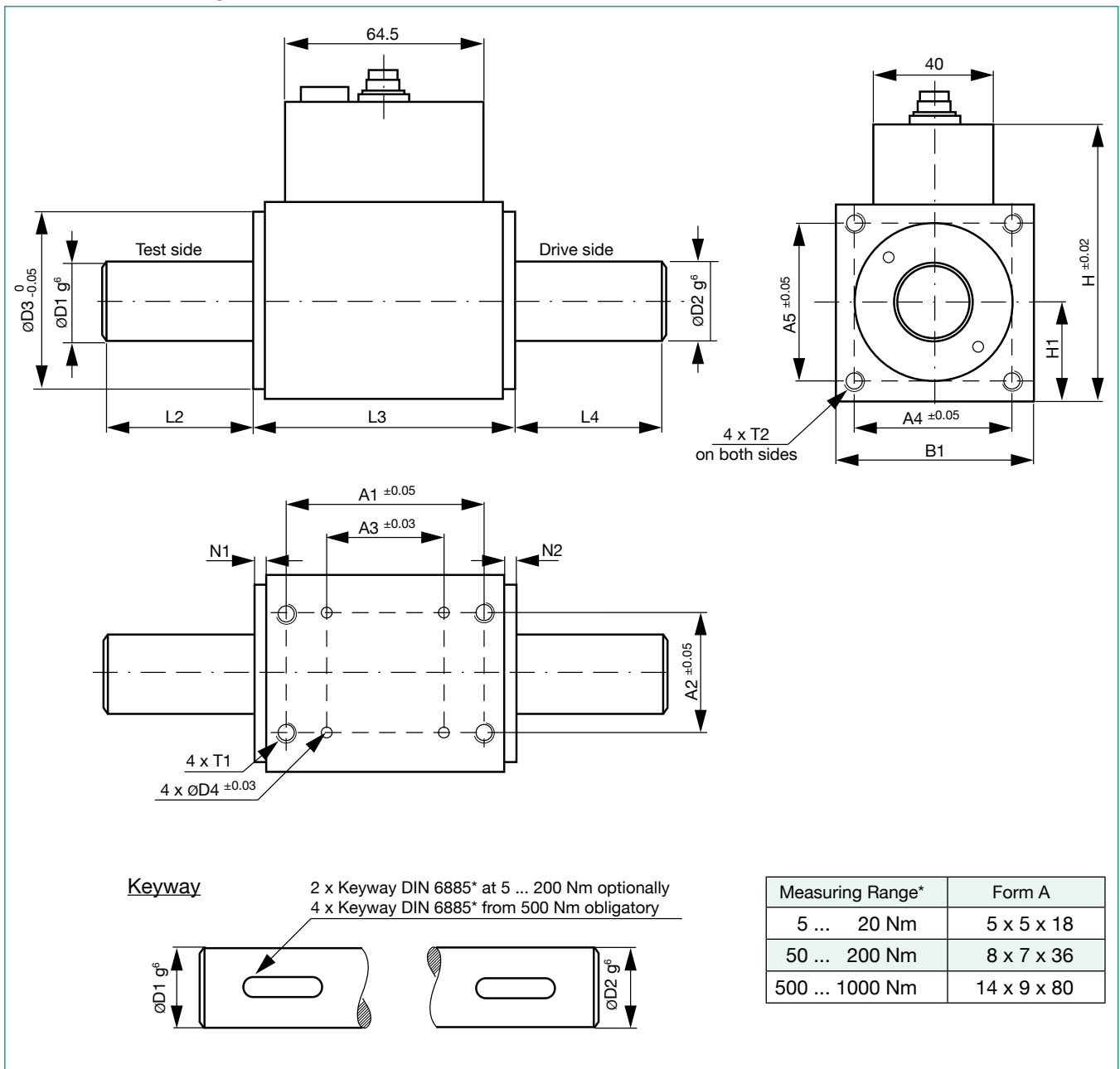
Dimensional drawing

Specifications, based on measurement range Table 2

Order Code	Measurement Range [Nm]	Spring Constant [Nm/rad]	Mass Moment of Inertia Drive Side [10 ⁻⁶ kg*m ²]	Mass Moment of Inertia Measuring Side [10 ⁻⁶ kg*m ²]	Maximum Permissible Axial Load [N]	Maximum Permissible Radial Load [N]	Weight [g]	Max. Rotary Speed** [min ⁻¹]
8661-4020-V0XXX	0 ... ± 0.02	10	2.2	0.048	50	3	300	25 000
8661-4050-V0XXX	0 ... ± 0.05	10	2.2	0.048	50	3	300	25 000
8661-4100-V0XXX	0 ... ± 0.1	20	2.2	0.048	50	3	300	25 000
8661-4200-V0XXX	0 ... ± 0.2	50	2.2	0.05	50	3	300	25 000
8661-4500-V0XXX	0 ... ± 0.5	100	2.2	0.06	50	4	300	25 000
8661-5001-V0XXX	0 ... ± 1	100	2.2	0.062	50	7	300	25 000
8661-5002-V0XXX	0 ... ± 2	180	2.2	0.077	50	13	300	25 000
8661-5005-V0XXX	0 ... ± 5	800	14.3	2.2	200	15	900	15 000
8661-5010-V0XXX	0 ... ± 10	1700	14.3	2.35	200	30	900	15 000
8661-5020-V0XXX	0 ... ± 20	3000	14.6	2.6	200	60	900	15 000
8661-5050-V0XXX	0 ... ± 50	14000	85.7	33.30	300	125	1500	15 000
8661-5100-V0XXX	0 ... ± 100	25000	85.9	33.70	300	215	1500	15 000
8661-5200-V0XXX	0 ... ± 200	40000	87.5	35.00	300	215	1500	15 000
8661-5500-V0XXX	0 ... ± 500	150000	1200	600.00	500	250	6000	7000
8661-6001-V0XXX	0 ... ± 1000	220000	1200	600.00	500	500	6000	7000

** Max speed with option angle and speed measurement refer to page 5.

Sensor with 2 Measurement Ranges (option)

The sensor with two measuring ranges has the same dimensions as the standard version but it also has two different calibrated measuring ranges.

The dual range sensor offers significant advantages:

1. With a single sensor a very wide range of torques can be measured accurately.
2. Good overload protection particularly in smaller measuring ranges: For the smaller measuring range the sensor provides the overload protection of the larger measuring range.
3. No retooling time at all and only one coupling pair is needed.

Possible ratio of dual ranges sensor:

- ▶ 1:4
- ▶ 1:5
- ▶ 1:10

With the sensor with the 12 pin connector the measuring range is switched by applying a voltage level whose magnitude and whose ground reference correspond to the control signal. (For measuring range 1:1, 0 ... 3 V, for the extended measuring range 10 ... 30 V).

The switching time is max. 50 ms.

Typical applications of the dual range sensor are:

- ▶ Test stands for motors, turbines and gears, extruders
- ▶ Engineering
- ▶ Drive engineering
- ▶ Aeronautics and space sector
- ▶ Automotive
- ▶ Product development
- ▶ Quality assurance

Specification, based on measurement range Table 3

Order Code	Upper Range Value [Nm]	Measuring Range Extension End Value Second Range		
		1:10	1:4	1:5
8661-4500-VX000*	0 ... ± 0,5	-	-	± 0.1 Nm
8661-5001-VX000*	0 ... ± 1	-	-	± 0.2 Nm
8661-5002-VX000*	0 ... ± 2	± 0.2 Nm	± 0.5 Nm	-
8661-5005-VX000*	0 ... ± 5	± 0.5 Nm	-	± 1 Nm
8661-5010-VX000*	0 ... ± 10	± 1 Nm	-	± 2 Nm
8661-5020-VX000*	0 ... ± 20	± 2 Nm	± 5 Nm	-
8661-5050-VX000*	0 ... ± 50	± 5 Nm	-	± 10 Nm
8661-5100-VX000*	0 ... ± 100	± 10 Nm	-	± 20 Nm
8661-5200-VX000*	0 ... ± 200	± 20 Nm	± 50 Nm	-
8661-5500-VX000*	0 ... ± 500	± 50 Nm	-	± 100 Nm
8661-6001-VX000*	0 ... ± 1000	± 100 Nm	-	± 200 Nm

*X = 1: range extension 1:10, X = 2: range extension 1:5, X = 3: range extension 1:4

Torque Sensor with integrated USB Interface (option)

- Includes powerful data acquisition software DigiVision
- Plug & Measure
- Numerical and graphical display of torque/speed/mechanical power as well as editable mathematical factors/results, etc.
- Suitable for mobile use with a notebook
- Power supply via the USB-port (External power supply is not required)
- DLL and LabView-driver for free



This sensor version has an USB-port instead of the 0 ... ± 10 V output. The measurement signal is transferred digitally from the measuring shaft and then transmitted serially. This allows a PC-based evaluation of the measurement signals.

Beside torque, speed or angular displacement measurement values are provided optionally. The DigiVision software displays the mechanical power values also calculated by the sensor.

Configuration and Evaluation Software DigiVision

Multichannel configuration and evaluation software suitable for easy PC-based analysis and reporting in mobile and stationary applications field such as lab, R & D and industrial environment.

DigiVision Features

- ▶ Numerical and chart representation of the torque, speed, angle and mechanical power
- ▶ Intuitive user interface
- ▶ Automatic sensor detection
- ▶ Practical start and stop trigger features
- ▶ 4 limits per channel configurable
- ▶ Peak value memory for MIN/MAX
- ▶ Auto scale
- ▶ Storage function of the measuring log as Excel or PDF file
- ▶ Archive viewer including curve array display
- ▶ Multichannel operation with full version possible also with other sensors, e.g. 8625, 9206
- ▶ Calibration data are stored in the sensor

Signal processing

Measuring rate:

- up to 200 meas./s (with 8661-P001) for each channel
- up to 400 meas./s (with 8661-P100) for each channel
- up to 1000 meas./s (with 8661-P200) for each channel

A/D conversion 16 bit

Operating System requirements

Windows 2000, XP, Vista, Windows 7, Windows 8 und Windows 10

Accessories

Configuration and evaluation software DigiVision for torque / speed / mechanical power (up to 200 meas/s supply with the device)

8661-P001

Configuration and evaluation software DigiVision with option for torque / speed / mechanical power up to 400 meas/s for up to 16 channels

8661-P100

Configuration and evaluation software DigiVision with option for torque / speed / mechanical power / editable mathematical auxiliary channel, max. 1000 meas/s for up to 32 channels

8661-P200

USB cable with screwing, 2 m length (included)

8661-Z010

DigiVision is available in three versions:

DigiVision, 8661-P001 (included)

- For a single sensor only
- Max. 200 measuring values per second

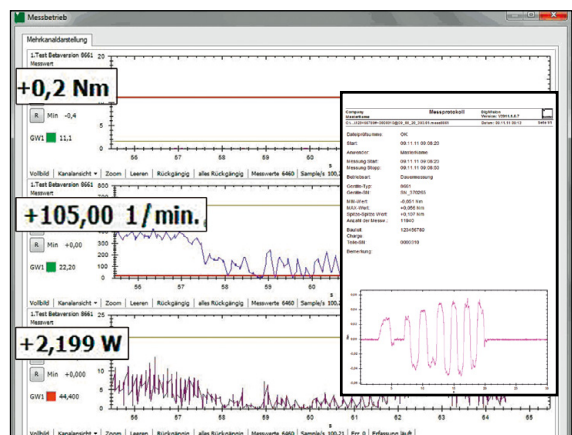

Screenshot P001: Multichannel display of a single sensor, below right: printed measuring record

DigiVision, 8661-P100, 8661-P200

- For more sensors, up to 16 channels (up to 32 channels*)
- Max. 1000 measuring values per second, per channel*
- Display per sensor (depending on the sensor type)
 - torque and / or angle or
 - torque / speed / mechanical power
 - editable mathematical auxiliary channel*

*for 8661-P200 only

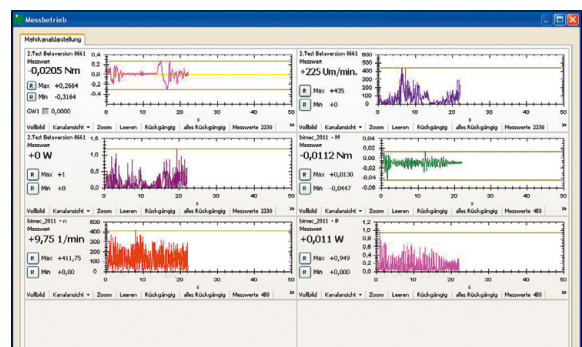

Screenshot P100: Multichannel display of two sensors, torque / speed / mechanical power

Torque sensor with integrated rotational speed / angular displacement measurement (option)

8661 torque sensors are optionally available with integrated rotational speed and angular displacement measurement. Two pulse channels – channel A and channel B – are always available.

For clockwise rotation (looking at the drive end), channel A leads channel B with a phase shift of 90°.

Only one pulse channel is needed for speed measurement.

For angular displacement measurement (or direction detection), both channels need to be evaluated. To achieve the maximum angular resolution, the rising and falling edges should be read out with four-edge evaluation.

Angular displacement measurement* (angular resolution with four-edge evaluation):

Encoder disk with 2000 increments:	0,045°
Encoder disk with 1024 increments:	0.088°
Encoder disk with 400 increments:	0.225°
Encoder disk with 240 increments:	0.375°

Speed measurement*:

Encoder disk with 2000 increments:	≤ 3 000 min ⁻¹
Encoder disk with 1024 increments:	≤ 6 000 rpm
Encoder disk with 400 increments:	≤ 15 000 rpm
Encoder disk with 240 increments:	≤ 25 000 rpm

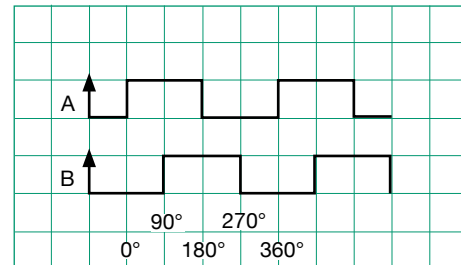

* Not all angular displacement / speed options are available for every measurement range.

	0.02 Nm ... 2 Nm	5 Nm ... 200 Nm	500 Nm ... 1000 Nm	Versions
2000 incr.	-	yes	yes	-Vx4xx
1024 incr.	yes	yes	yes	-Vx2xx
400 incr.	yes	yes	-	-Vx1xx
240 incr.	yes	-	-	-Vx3xx

Accessory metal bellow coupling series 8690



Metal bellow couplings for optimum compensation of misalignments

For optimum compensation of misalignment we recommend torsionally free metal bellow couplings. They are characterized by their excellent torsional stiffness during torque load and their low restoring forces. Whenever a rotational movement has to be transmitted, these couplings should be used.

The compensation of misalignment is beside torque transmission the second essential function of a coupling. Generally, misalignments are classed in three categories.

	Axial misalignment This is change in length along the longitudinal axis of the drive shafts relative to each other.
	Angular misalignment This misalignment is caused by assembly related offsets of the drive shaft to the output shaft.
	Lateral misalignment This misalignment is a parallel offset of both shafts.

For further information please see accessories data sheet.

Accessory mounting block model 8661-Z00X



If the sensor is removed and refitted quite often it is recommendable to mount it permanently.

The mounting block has a central hole and special design allowing a range of options for reliable cable attachment. Two clips ensure the sensor is fixed securely.

For measuring ranges < 100 Nm (because of the load from its own weight) and at higher speeds of 10,000 rpm and above (because of resonance effects), the sensor housing should be mounted on the existing mechanical structure.

A mounting block is provided for this purpose.

For further information please see accessories data sheet.

Technical data

Electrical values

Rated supply voltage range U_s :	10 ... 30 V DC
DC power consumption (without option):	approx. 2 W
Output voltage at \pm rated torque (sensitivity):	\pm 10 V
Output impedance:	1 k Ω
Insulation resistance:	> 5 M Ω
Sampling rate:	400 Hz*
Ripple:	< 50 mV
Calibration signal:	10.00 V DC
Drive signal (pin K):	10 ... 30 V DC
*Sampling rate 1000 Hz:	on request

Electrical connection

Standard sensor:	12 pins connector art. 9940
USB sensor (option):	Mini USB with screwing
Power pack:	Plug diameter 5.7 mm, center pin 2.0 mm (Supply and measuring channel are galvanically isolated)

Speed/angular displacement measurement (option)*

Output without external circuit:	TTL level
Output with external circuit:	Open Collector
Internal pull-up resistor:	2 k Ω (5 V level)
External circuit (Open Collector):	$U_{max} = 30 V / I_{max} = 30 mA$
Angular displacement measurement* (angular resolution with four-edge evaluation):	
Encoder disk with 2000 increments:	0.045°
Encoder disk with 1024 increments:	0.088°
Encoder disk with 400 increments:	0.225°
Encoder disk with 240 increments:	0.375°

Speed measurement*:	
For encoder disk with 2000 increments:	\leq 3 000 rpm
For encoder disk with 1024 increments:	\leq 6 000 rpm
For encoder disk with 400 increments:	\leq 15 000 rpm
For encoder disk with 240 increments:	\leq 25 000 rpm

* Please note: Not all angular displacement / speed options are available for every measurement range. For more information, see page 5.

Environmental conditions

Nominal and operating temperature range: 0 °C ... 60 °C

	Standard sensor	2nd meas. range dual range sensor
Effect of temperature on the zero signal	\pm 0.015 % F.S./K	\pm 0.03 % F.S./K
Effect of temperature on the sensitivity	\pm 0.01 % F.S./K	\pm 0.02 % F.S./K

Mechanical values

	Standard sensor	dual range sensor
Relative linearity deviation:		
Measuring range 0.02 to 0.05 Nm	$< \pm$ 0.1 % F.S.	$< \pm$ 0.1 % F.S.
Measuring range 0.1 to 1000 Nm	$< \pm$ 0.05 % F.S.	
Relative reversal error:		
Measuring range 0.02 to 0.05 Nm	$<$ 0.1 % F.S.	$<$ 0.2 % F.S.
Measuring range 0.1 to 1000 Nm	$<$ 0.1 % F.S.	
Relative tolerance of the sensitivity	\pm 0.1 % F.S.	\pm 0.2 % F.S.
Max. operating torque	200 % of rated torque	150 % of rated torque

Failure torque:	300 % of rated torque
Alternating load:	up to 70 % of rated torque
Material:	
Housing	anodized aluminium
shaft \leq 0.2 Nm, aluminium measuring shaft,	shaft ends made of stainless steel 1.4542
shaft \geq 0.5 Nm measuring shaft made of stainless steel 1.4542	
Degree of protection to EN 60529:	IP40
Weight:	see table 2/3
Fixing method:	see dimensional drawing page 2

Technical changes reserved. All data sheets at www.burster.com

Mounting Instructions

- ▶ Make sure that the connecting shaft is exactly aligned.
- ▶ Suitable couplings should be used to avoid strain resulting from parallel or angular offset between the shafts.
- ▶ Do not exceed permissible axial and radial forces (see table 2) during installation or operation.
- ▶ For detailed installation information, please refer to our operating manual (www.burster.com).

Accessories

12 pin mating connector (supplied with device)	9940
12 pin mating connector, 90°	9900-V539
Connecting cable, (torque and rotational angle/speed), length 3 m, one end open	99540-000F-0520030
Connecting cable, length 3 m, from 8661 without angle/speed measuring option to 9163 of housing	99209-540E-0160030
to 9206-V3xxxx and 9311	99209-540J-0090030
Connecting cable, length 3 m, 8661 to DIGIFORCE® 9307 combined channel D (option channel)	99163-540A-0150030
Adapter cable to DIGIFORCE® 9307 standard channel A/B and C (usable only in connection with type 99163-540A-015xxxx)	99209-215A-0090004
Power pack for external supply	8600-Z010
Mounting block (see page 5)	
measurement range 0 ... \pm 0,02 Nm up to 0 ... \pm 2 Nm	8661-Z001
measurement range 0 ... \pm 5 Nm up to 0 ... \pm 20 Nm	8661-Z002
measurement range 0 ... \pm 50 Nm up to 0 ... \pm 200 Nm	8661-Z003
measurement range 0 ... \pm 500 Nm up to 0 ... \pm 1000 Nm	8661-Z004
Couplings	Series 8690
Display and evaluation instruments	
Torque	e.g. SENSORMASTER 9163
Torque and angle	e.g. DIGIFORCE® 9307 see product section 9

Order Code

Torque sensor	8661-XXXX-V	<input type="checkbox"/>	<input type="checkbox"/>	<input type="checkbox"/>	<input type="checkbox"/>
Standard sensor	0				
Sensor with dual range 1:10	1				
Sensor with dual range 1:5	2				
Sensor with dual range 1:4	3				
Without angle/speed measurement	0				
Angle measurement 400 increments / Speed measurement	1				
Angle measurement 1024 increments / Speed measurement	2				
Angle measurement 240 increments / Speed measurement	3				
Angle measurement 2000 increments / Speed measurement	4				
Output voltage 0 ... \pm 10 V	0				
USB interface	1				
Output voltage 0 ... \pm 5 V	2				
Round shaft ends	0				
Shaft ends with keyway (Keyway to DIN 6885, Bl. 1)	2				

Order Information

8661 with 100 Nm measuring range, with high-resolution angular displacement measurement, 1024 increments. Option: 2nd measuring range 0 ... 20 Nm with USB interface including measurement and evaluation software 8661-P001 **8661-5100-V2210**

Manufacturer Calibration Certificate (WKS)

Calibration of a sensor or a measuring chain, clockwise and/or counterclockwise torque in 20 % steps, increasing and decreasing.