

Universal Instrumentation Amplifier for strain gage, potentiometric, DC/DC and incremental sensors

MODEL 9250

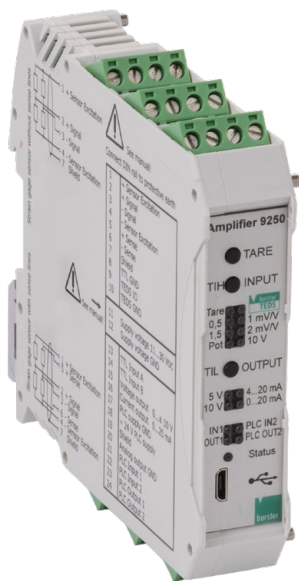

Highlights

- Ultra-fast pushbutton configuration
- Non-linearity < 0,005 % F.S.
- Outputs ± 10 V, ± 5 V and 0 (4) - 20 mA
- 6 wire technique
- Automatic sensor recognition due to burster TEDS
- Adjustable cut-off frequencies
- Versatile configuration using DigiVision PC software via USB port

Options

- Digital I/O to the PLC
- Increased sampling rate up to 14400 Meas./s.
- Interface for the connection to fieldbus controller 9251
- TTL input for incremental sensors

Applications

- All areas of mechanical engineering
- Assembly and joining equipment
- Hydraulic presses
- Measurement of cable strengths

Product description

The new 9250/9251 amplifier generation unites all the features that make modern measurement data acquisition actually possible for the first time. Network-compatible, high-precision, user-friendly, smart and versatile: the combined system of amplifier module and fieldbus controller can be integrated into any existing setup. The amplifier 9250 takes signals exactly to the point where they can be combined, monitored and linked efficiently to other data. The fieldbus interfaces give you flexibility, speed and perfect connections, and save you time, money and other resources when integrating your measurement setup with existing systems. Automatic sensor recognition due to burster TEDS lets you play absolutely safe, protecting you from setting incorrect parameters.

The broad supply voltage range permits operation on standard power supplies used in switch gear cabinets. A highly accurate precision amplifier performs the amplification of the sensor signal being applied. The latest microprocessor technology made a 24 bit AD conversion with high accuracy possible. The sensor excitation is performed by the amplifier module itself so that no additional voltage source is required. It can also be set in steps of 2.5 V, 5 V, 10 V using configuration software DigiVision. The maximum feed current of 40 mA permits parallel connection of several strain gages sensors, e.g. for the addition of measurement variables. Measurement errors brought about by varying line lengths or due to temperature fluctuations effecting the sensor cable are avoided by having probe lines measuring the actual feed voltage directly on site at the sensor itself (6 wire technology). The cut-off frequency of the amplifier can be switched between 10 Hz and 1 kHz.



Instrumentation amplifier 9250 with bus interface for 9251



Fieldbus controller 9251



Fieldbus controller 9251 with up to 8 instrumentation amplifiers 9250

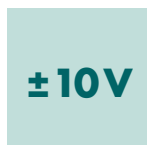

Technical Data

Connectable sensors		
Strain gage full bridge		
Excitation voltage		2.5 / 5 / 10 V, configurable, short-circuit proof
Connection technology		4 or 6 wire, automatic recognition
Excitation current		approx. 40 mA
Input impedance		1 GOhm
Measuring ranges		±15 mV, ±30 mV, ±300 mV
Potentiometer		
Excitation voltage		5 V
Excitation current		max. 40 mA
Resistance		> 200 Ohm
Input impedance		1 GOhm
Voltage metering		
Measuring range		±10 V
Input impedance		1 GOhm
TTL inputs		
Level		TTL, 5V, approx. 3 mA, galvanically isolated from amplifier
Counter depth		32-bit, 4 counter increments
Cut-off frequency		2 MHz
Analog outputs		
Voltage outputs		±5 V or ±10 V
Internal resistance		100 Ohm
Current output		0 ... 20 mA or 4 ... 20 mA, Load 50 up to 500 Ohm
Filter		without, opt. 4 Hz - 700 Hz in steps active at a measuring speed of 7200 meas./s.
PLC IO		
Two inputs		PLC level DIN 61131
Function		Tare, peak-value buffer reset, limits reset, HOLD, counter reset
Response time		20 ms
Two outputs		PLC level DIN 61131, p-switched, max. 500 mA, 24 V external supply necessary, Inputs and outputs galvanically isolated from amplifier, Function configurable via USB
Function		Above limit, below limit, window modus
Response time		< 0.5 ms
Internal communication bus to the fieldbus controller 9251		
Transmission speed		3.6 kHz
Housing		
Material		polyamides, metal housing inside
Dimensions		115 x 110 x 22.5 mm (D x H x W)
Weight		approx. 210 g
Protection class		IP20
Connections		Screw clamps, up to 2.5 mm ²

Technical Data

General data	
Supply voltage	11 ... 30 V DC, Galvanic separation, overvoltage and pole protection
Power consumption	approx. 3 W
Sensor recognition	burster TEDS
Operating temperature range	0 ... +50 °C
Storage temperature range	-25 °C ... +70 °C
Humidity	0 ... 70 % non condensing
Cut-off frequency	500 Hz at 1200 Meas./s. (standard), signal running time 1,9 ms 3000 Hz at 14400 Meas./s. (option), signal running time 0,4 ms
Installation	grounded mounting rail 35 mm to DIN EN 50022
Electrical isolation	Instrumentation amplifier, TTL inputs, PLC IO, supply voltage
Error limit	±0.03 % F.S.
AD conversion	24-Bit
DA conversion	16-Bit
Max. measuring rate	14400 (option), 1200 standard Meas./s.
Non-linearity	< 0.005 % F.S.
Temperature coefficient Gain	< 15 ppm/K Rd
Input zero drift	< 0.1 µV/K
Common mode rejection (CMRR)	140 dB (Bei DC)
Interfaces	Micro USB for configuration
Ripple & Noise at voltage output	approx. 5 mVss at 1200 meas./s
Other	Teach-in via button, tare function via button, I/O configuration via button or USB

Block diagram – **9250-VXXXXX0X**

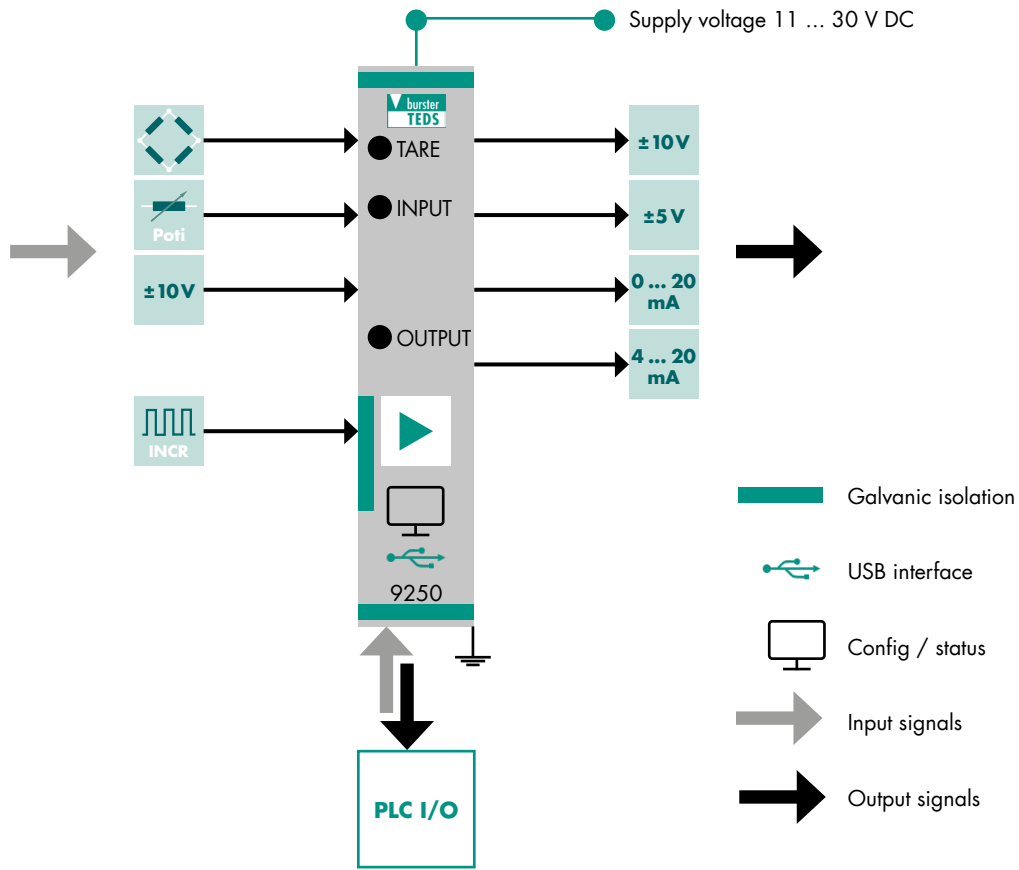

Block diagram – **9250-VXXXX1X (bus compatible)**

Supply voltage
11 ... 30 V DC

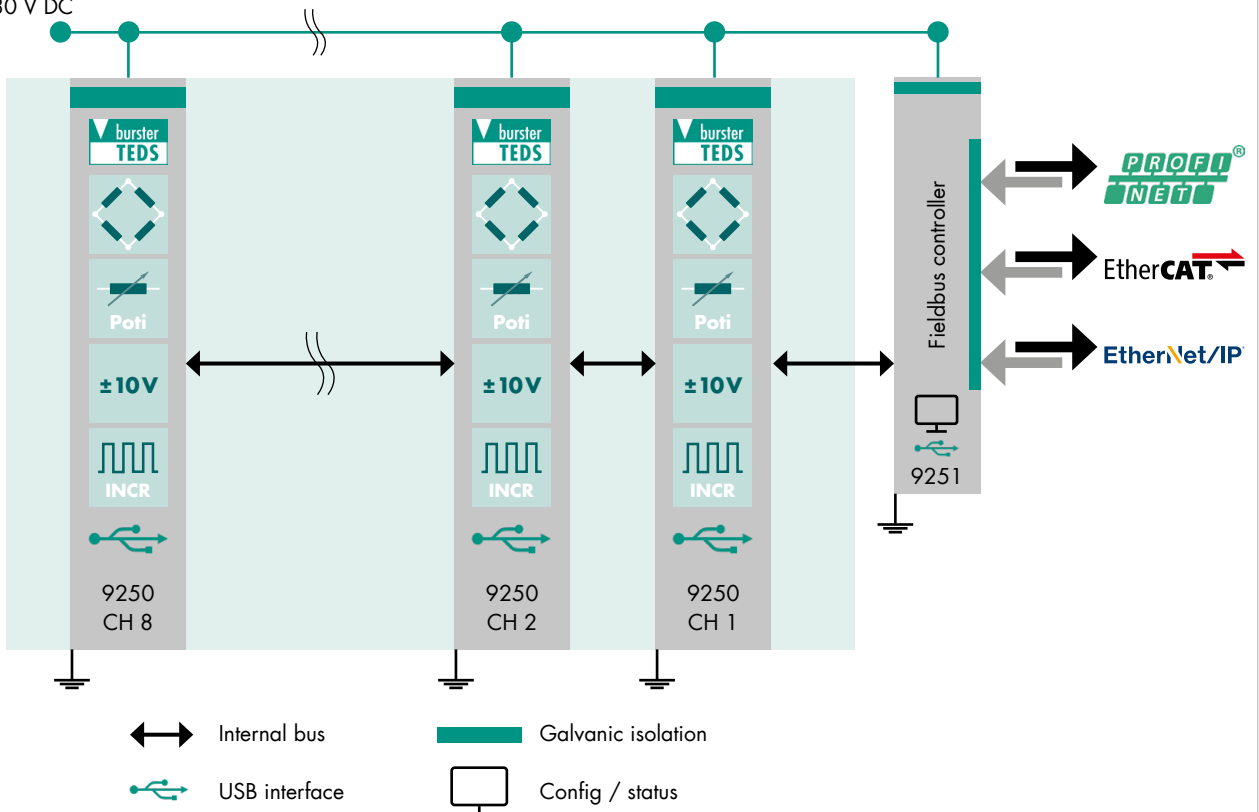

Pin assignment

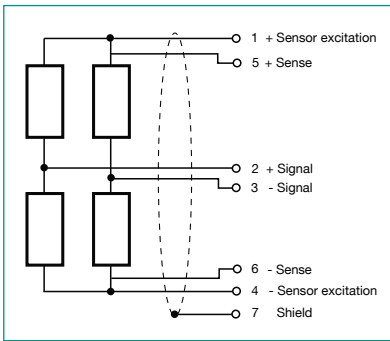

Strain gage 6 wire

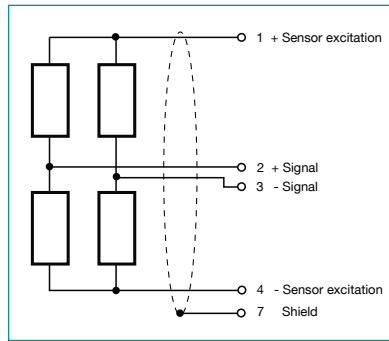

Strain gage 4 wire

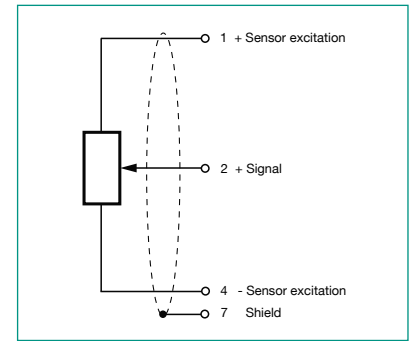

Poti

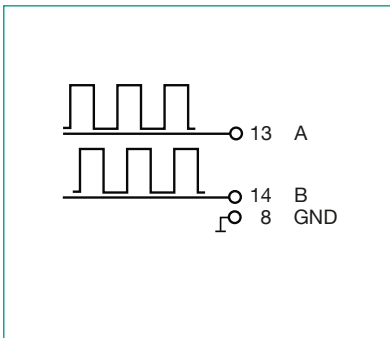

Counter

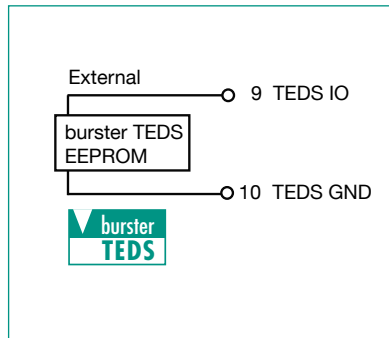

TEDS

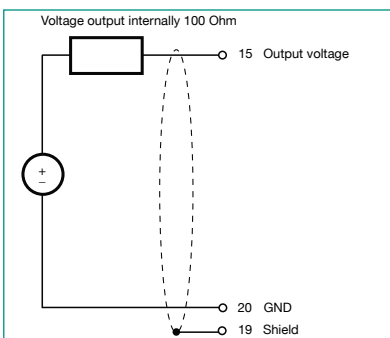

Output Voltage

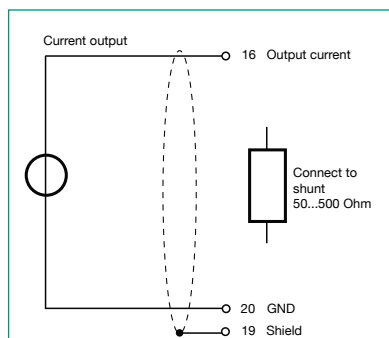

Output current

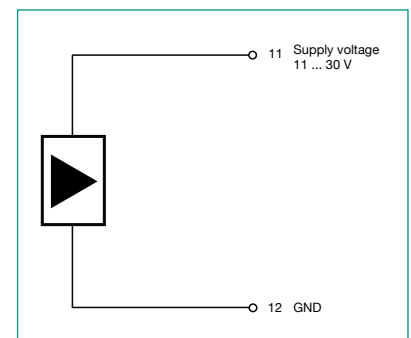

Supply voltage

DigiVision PC Software

The amplifier module model 9250 is used wherever measurement signals from strain gage, potentiometric, DC/DC or incremental sensors have to be converted into standard signals. Simply by mounting on conventional DIN-mount rails, it is possible to position the amplifier module on location, in the proximity of the sensor.

- Convenient device configuration via front-panel USB port
- Automatic recognition of amplifier modules in DigiVision
- Manage a range of parameter sets
- Backup facility for storing settings
- Choice of output parameter (current or voltage)
- Manual configuration of calibration data in the module
- Simplified measuring operation for service purposes
- Easy parameterization of the measurement input
- Scale value parameterization for connection to fieldbus controller 9251

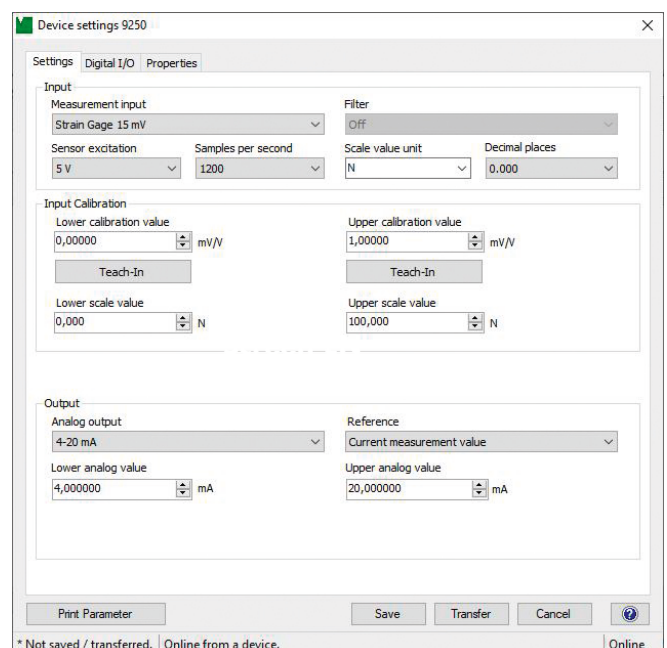

Ultra-fast pushbutton configuration

- ▶ Select input
- ▶ Select output
- ▶ Get started

Accessories

Order Code	
9900-K358	USB cable for configuration
9250-Z001	1 set of terminals (included in scope of delivery)

Adjustment for measurement chains

Adjustment	
92ABG	Compensation of measurement chain in preferential direction of the sensor of output 10 V
92ABG-S	Compensation of measurement chain according to customer request
92ABG-2 (at TEDS)	Compensation of measurement chain with TEDS sensors of output 10 V

Calibration certificate with accreditation symbol

Calibration certificate with accreditation symbol for Instrumentation amplifier 9250. The calibration is based on the accreditation of the calibration laboratory D-K-15141-01-00 for the scope of accreditation listed in the annex. The traceability to national standards as well as wide international recognition (DAkkS as a signatory of the multilateral agreements of EA, ILAC and IAF) are guaranteed.



Calibration certificates for instrumentation amplifiers

Standard factory calibration certificate for instrumentation amplifiers (WKS)	
On request	Calibration is performed by electrical simulation of the input variables.
Calibration certificate with accreditation symbol for instrumentation amplifiers (DKD)	
On request	Our ISO 17025 accredited calibration laboratory (DAkkS) offers accredited calibration certificates according to its scope of services. Calibration is performed by electrical simulation of the input variables.

Calibration certificates for measurement chains

Standard factory calibration certificate for measurement chains (WKS)	
Optional available	Normally, our standard factory calibration certificate contains measuring points which are recorded starting from zero in 5 steps (distributed as evenly as possible over the measuring range) until the nominal sensor value is reached. In this process, the change of the physical input variable takes place with increasing and decreasing signal with unchanged installation position of the sensor. Calibration is performed in conjunction with a transducer (sensor) for physical quantities and is based on the procedure specified in the sensor data sheet.
Special factory calibration certificate for measurement chains (WKS)	
On request	We are happy to calibrate sensors and measurement chains to the customer's specification.
Calibration certificate with accreditation symbol for measurement chains (DKD)	
Optional available	Our ISO 17025 accredited calibration laboratory (DAkkS) offers accredited calibration certificates according to its scope of services. The applied calibration procedures can also be taken from the data sheet of the used transducer (sensor). Calibration is performed in conjunction with a transducer (sensor) for physical quantities.

Order Code

						Standard					
						0	0	0	0	0	0
9	2	5	0	-	V						
Housing version											
■ IP20 mounting rail housing						0					
Input signal											
■ Strain gage, poti and normalized signal						0					
■ Strain gage, poti, normalized signal and TTL						1					
Output signal											
■ Analog output ± 10 V and 0 (4) ... 20 mA							0				
PLC interface											
■ without								0			
■ Digital I/O (2 inputs and 2 outputs)								1			
Multi-channel operation with fieldbus controller											
■ without bus interface									0		
■ with bus interface for fieldbus controller									1		
Sampling rate											
■ Sampling up to 1200 Meas./s.										0	
■ Sampling up to max. 14400 Meas./s.										1	